

664. Dynamic processes of a vehicle moving over step-shaped obstacles

A. Dargužis^{1a}, J. Sapragonas^{1b}, K. Pilkauskas^{2c}

¹Kaunas University of Technology
Kęstučio str. 27 LT-44312 Kaunas, Lithuania

²Kaunas University of Technology
Mickeyvičiaus str. 37 LT-44244 Kaunas, Lithuania

E-mail: ^a andrius.darguzis@ktu.lt, ^b jonas.sapragonas@ktu.lt, ^c kestutis.pilkauskas@ktu.lt

(Received 10 July 2011; accepted 5 September 2011)

Abstract. The study presents the development and analysis of a dynamic model, which simulates the loads induced on a tire of a vehicle as well as its suspension elements including their deformations when passing over a step-shaped obstacle. The possibilities of application of the quarter- and half-car models are considered. The models are used to analyze the influence of vehicle mass and suspension parameters on dynamic loads with the aim to provide recommendations and requirements for the development of active suspensions enabling to reduce dynamic loads generated when crossing over the considered obstacles.

Keywords: car dynamic model, sprung mass, unsprung mass, step-shaped obstacle.

Introduction

Investigation of movement of vehicles on roads with different pavements leads to very contradicting requirements for suspensions. The opinion currently prevails that it is a complex task to both ensure suspension parameters enabling high-level comfort of a low mass vehicle and to make them compatible with the other function of the suspension – to ensure constant contact between the tire and the pavement. Recently the researchers put great efforts in developing mechatronic suspensions – active suspensions with computer controlled mechanical (hydraulic, pneumatic, electromechanical) actuators [1, 2]. Investigations of the problems in the application of such systems reveal the obvious lack of control algorithms suitable for these systems. Solution possibilities for the problem are limited by the fact that the range of movement conditions is very wide, thus setting the need to limit pavement parameter range when developing control algorithms.

Aim of the research is to analyze performance of the suspension in case of vehicle movement across the most dangerous obstacle – step-shaped pavement unevenness. Although the problem is considered to be the classical one [3, 4], the universal recommendations for selecting tire characteristics and suspension stiffness [5, 8, 9] and elaborating control algorithms for parameter adjustment of active suspensions do not exist. Behavior of the vehicles which differ significantly in mass and tire characteristics moving across step-shaped bumps is compared. A quarter-car model and a 2D car model are used for the simulations.

Characteristics of the research object

This study considers a high-mobility (EHMV type) vehicle [6, 7], which was designed on the basis of GAZ 66 vehicle at the department of Transport Engineering of KTU, as well as the popular car VW Golf. Data of the analyzed vehicles is presented in Fig. 1 and Table 1. For the simulation of EHMV vehicle the regulated pressure tires 14,00-20 were used, while for the vehicle VW Golf - the tires 175/70R13 were selected on the basis of recommendations of its manufacturer. Characteristics of the tires are listed in Table 2 [10]. The presented data indicates that the ratios of masses and tire diameters are equal. Thereby a sufficiently wide range of parameters is covered.

Table 1. Vehicle characteristics

Vehicle	Mass, kg	L , mm	a^* , mm	b^* , mm	h_c^* , mm	I_y , kgm ²
EH MV	7481	3300	1572	1728	870	21320
VW Golf	995	2475	994	1481	405	13220

* a , b , h_c parameters are defined in Fig. 4 b.

Table 2. Tire characteristics

Tire	Allowable load, N	Diameter D , mm	Static radius R_{st} , mm	Width B , mm	Pressure, bar	Stiffness, kN/m
14.00-20	25000	1260	583	390	3.2	532*
175/70R13	4750	586	261	177	2.0	148*

* In case of 3.2 MPa pressure.

Dynamical models

In crossing a step-shaped unevenness by a transport mean a leveling function of the tire is of special importance. That is why for the simulation of the crossing of the step-shaped unevenness a special calculation scheme has to be developed. For the purpose the schemes for mobility determination are used [3, 4, 7]. Moving on a step is modeled in three phases (Fig. 1).

- Coming into contact – the wheel moves horizontally, the tire starts to be deformed (Fig. 1, a). Due to tire deformation vertical component of reaction R which appears at the contact point lifts the tire till the contact with the pavement is lost.

- Further motion of the tire is its rotation about the contact point (Fig. 1, b). Preliminary analysis of the model revealed that radius of the tire changes insignificantly at this phase and has no essential influence on the trajectory of the wheel axis.

- The tire moves on even horizontal surface (Fig. 1, c). Its deformation is caused by vertical reaction R_z and further goes onto dynamical processes.

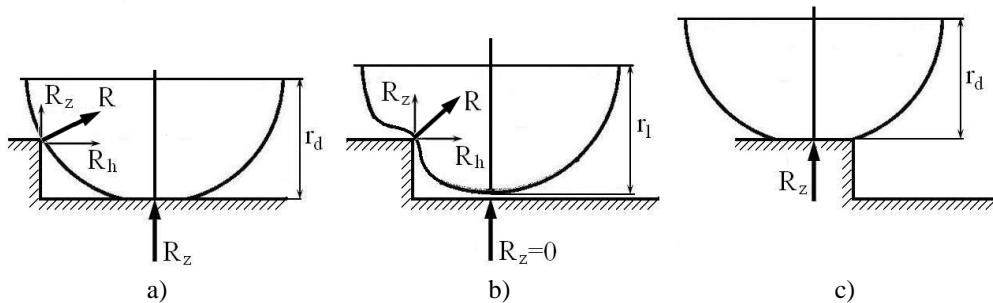

Fig. 1. Scheme of tire deformation

The following additional conditions were assumed for the models:

- The vehicle moves in horizontal direction with constant velocity – horizontal component of reaction R has no influence on dynamical phenomena in longitudinal direction. As preliminary calculations revealed this is valid for the steps of comparably low height.

- The vehicle approaches the obstacle in uniform motion, i.e. up to the obstacle there are no excitation sources which might influence dynamical phenomena in longitudinal (accelerations of the vehicle) and vertical (operation of the suspension) directions.

- The vehicle moves with constant velocity v , torque developed by its engine is sufficient to cross the obstacle with no change in the velocity.

- Stiffness characteristic of the tire is linear.

Calculation scheme applied for the modeling of the crossing process is presented in Fig. 2. Dynamical processes are described by the equations:

$$\begin{cases} (m_1 + m_2)\ddot{y} + h_p\dot{y} + c_p y + h_{ey}\dot{y} + c_{ey}y = 0 \\ (m_1 + m_2)\ddot{x} + h_{ex}\dot{x} + c_{ex}x = F \end{cases} \quad (1)$$

where: $(m_1 + m_2)$ – lumped mass element representing unsprung and sprung masses accordingly; x, y – coordinates of the lumped mass element with respect to the coordinate system YOX ; c_p – stiffness of the tire in case of flat surface contact, h_p – damping factor of the tire in case of flat surface contact, F – external force.

Stiffness and damping factors of the tire in case of edge contact can be expressed as:

– Stiffness and damping factors in vertical direction (along y axis):

$$c_{ey} = c_e \sin^2 \varphi, \quad h_{ey} = h_e \sin^2 \varphi \quad (2)$$

– Stiffness and damping factors in horizontal direction (along x axis):

$$c_{ex} = c_e \cos^2 \varphi, \quad h_{ex} = h_e \cos^2 \varphi \quad (3)$$

where: c_e – stiffness factor of the tire in case of edge contact, h_e – damping factor of the tire in case of edge contact.

Angular coordinate of the lumped mass element position can be expressed as:

$$\sin \varphi = \frac{K + y}{L - x} \quad (4)$$

where: $K = r - \Delta r - h$, $L = r \cos \varphi_0$ – constants, r – radius of the tire, h – height of the step obstacle, $\Delta r = \frac{(m_1 + m_2)g}{c_p}$ – static deformation of the tire due to the weight force of lumped mass element, g – acceleration due to gravity.

Initial angular coordinate is defined as:

$$\sin \varphi_0 = \frac{K}{r} \quad (5)$$

In case the condition $K + y \geq r$ is satisfied the terms $h_p\dot{y}$ and $c_p y$ in the system of equations (1) become equal to zero and the tire losing contact with pavement transits to the second phase of motion (Fig. 1), i.e. performs rotational motion about the step edge.

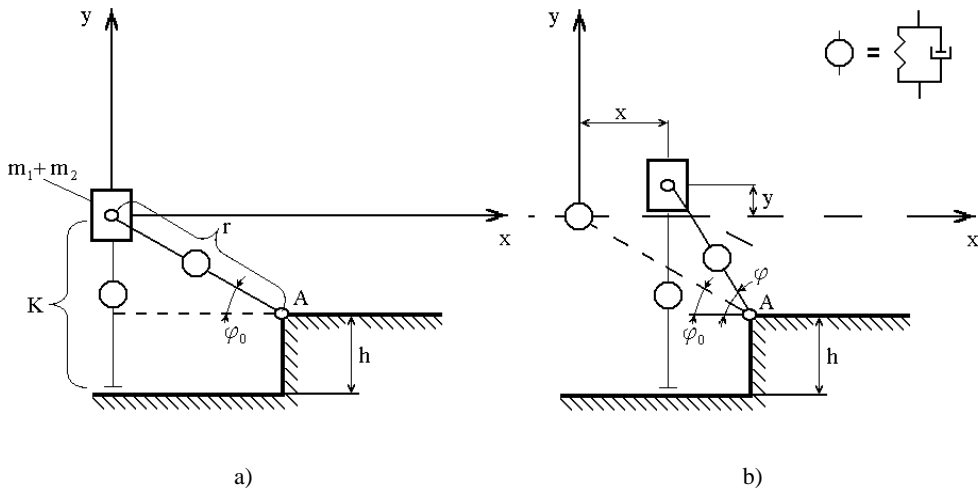

Fig. 2. Calculation scheme for the crossing over the step-shaped obstacle: a) the moment of initial tire - step contact, b) the phase of tire motion on the step

It is known that stiffness of the tire depends on the shape of contact surface. Therefore stiffness characteristics were determined experimentally deforming it by a flat surface and a punch imitating the step edge (metal angular bar was used). The experiment was performed at K. Vasiliauskas materials resistance laboratory of KTU using the Amsler tension-compression machine. For the experiment Goodyear Wrangler AR/R 245/75R16 tire was used. The obtained results are presented in Fig. 3. For further calculations it was accepted that stiffness of the tire when it is deformed by a step edge is 1.55 times lower.

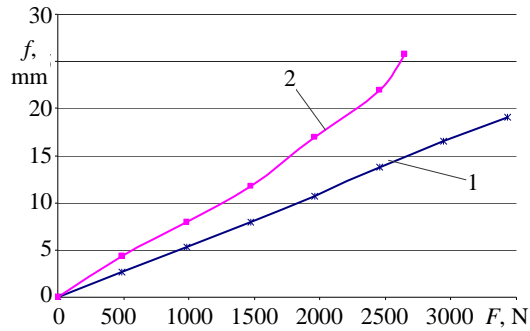

Fig. 3. Deformation versus load dependence for the tire Goodyear Wrangler AR/R 245/75R16: 1 – flat surface, 2 – angular bar

A computer program enabling to reconstruct trajectory of the wheel axis was elaborated based on the description of the above presented dynamical processes. This trajectory in subsequent simulations was used as a profile of unevenness taking into account the leveling function of the tire. Distance covered by the vehicle VW Golf till the encounter of the step is felt changes in the range from 0,1 m up to the radius value of the tire (0,32 m) when the step height changes from 25 mm to 150 mm (Fig. 4, a). The latter step height was used only for the sake of research interests as in real conditions such height is hardly imaginable. Speed of the vehicle as in the range used for the investigation (1.39-13,89 m/s) has no influence on the leveling function of the tire (Fig. 4, b). Tires of the greater diameter (when other conditions are identical) make the influence of the step-shaped obstacle smoother (Fig. 4, c) since at the initial moment the impact is smoothed more and the process of transition to the movement on horizontal plane becomes softer.

As the result of the performed analysis (on the basis of Eqs.1-5) a special subroutine is used in further simulations. It evaluates the leveling function of the tire for a specific step height and vehicle velocity.

Research results

Both a quarter- and half-car models (Fig. 5) were used for evaluation of the influence of suspension parameters. Table 3 lists the parameters of the models. With the aim to enable the application of the active suspensions the models support the possibility to modify suspension parameters. For the vehicle VW Golf two suspension cases – with linear and nonlinear elastic and damping elements are specified. Nonlinear characteristics are described taking typical characteristics of elastic elements in the region of static equilibrium and the stiffening characteristic for higher values of dynamic deformations and rebound. As damping elements the characteristics of typical shock absorbers used for VW Golf were taken. For EHMV two suspension variants – typical with coil spring elements and pneumatic suspensions were used (Table 3).

Displacements of sprung and unsprung masses obtained using different models are presented in Fig. 5. For the car VW Golf interrelation of the suspensions can be observed – in the case of the 2D model the mass m_{22} starts its motion when the front axis moves on the step. Nevertheless essential differences in dependences obtained with both models do not exist.

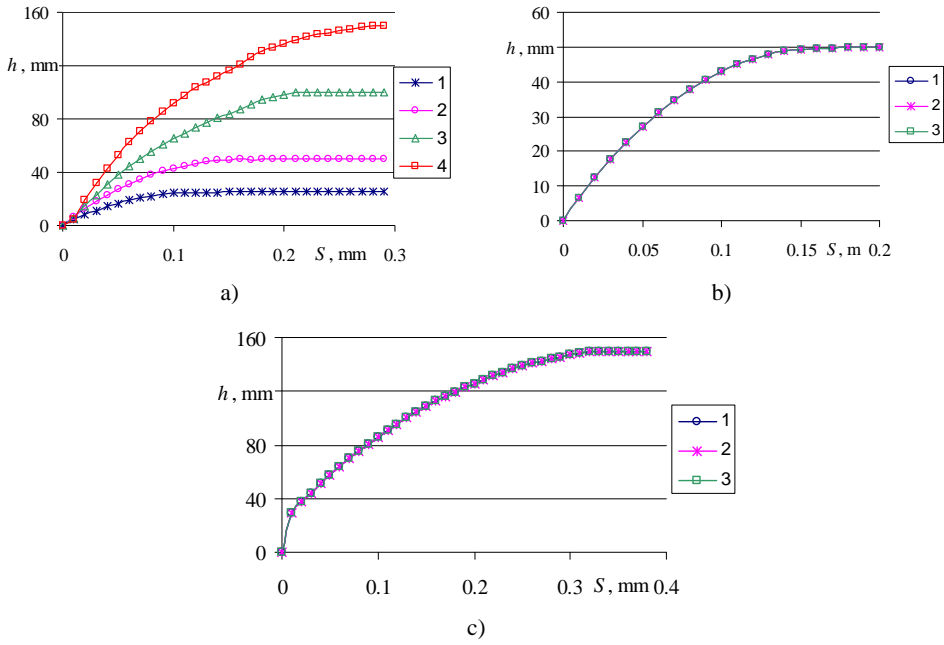

Fig. 4. Dependence of the calculated pavement profile taking into account the leveling function of the tire on step height (a) ($v = 4.17$ m/s; 1 – 25 mm, 2 – 50 mm, 3 – 100 mm, 4 – 150 mm), speed of the vehicle ($h = 150$ mm; 1 – 1.39 m/s, 2 – 2.78 m/s, 3 – 4.17 m/s) (b) and type of the tire (c) for the vehicles VW Golf (a-c), EHMV (c)

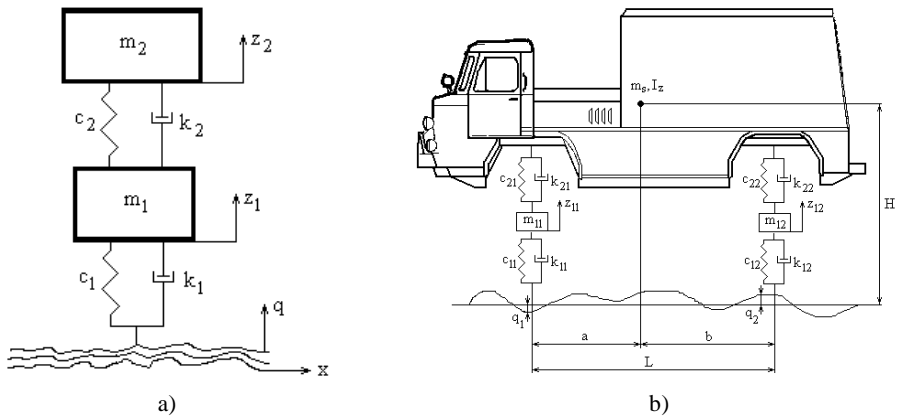

Fig. 5. a) A quarter-car model: m_1 , c_1 and k_1 – mass, stiffness and damping factor of the tire protector, c_2 , k_2 – stiffness and damping factors of the tire, c_3 , k_3 – stiffness and damping factors of the suspension, m_2 – unsprung mass, m_3 – sprung mass. b) A half-car (2D) model of the vehicle: c_{11} and k_{11} – stiffness and damping factors of the front tire, c_{12} , k_{12} – stiffness and damping factors of the rear tire, c_{21} , k_{21} – stiffness factor of the front suspension and damping factor of its shock absorber, c_{22} , k_{22} – stiffness factor of the rear suspension and damping factor of its shock absorber, m_{11} , m_{12} – unsprung masses in the front and rear parts of the vehicle, m_s – sprung mass, L – basis of the wheels, a and b – distances from the mass center to the front and rear axis accordingly, H – height of the mass center, I_z – mass moment of inertia with respect to longitudinal axis

Fig. 6 provides simulation results obtained with the quarter- and half-car models – displacements of sprung and un-sprung masses, when velocity of the vehicle equals to 1.39 m/s. The influence of the suspension parameters and the parameters ν and h on the loads on suspension and the tire are evaluated by dynamical coefficients:

$$k_{da} = \frac{z_2 - z_1}{f_{st}} \quad (6)$$

$$k_{d_{pa}} = \frac{z_1 - q}{f_{pa}} \quad (7)$$

where z_2, z_1 – displacements of sprung and unsprung masses from the position of static equilibrium, q – unevenness height, f_{pa} – static deformation of the tire.

Table 3. Parameters of a quarter-car model

Vehicle	C_1 , kN/m	C_2 , kN/m	k_1 , kNs/m	k_2 , kNs/m	m_{a1} , kg	m_{n2} , kg
EHMV coil spring type:	front	617	77	250	5.5	575
	rear	617	90	250	13	575
EHMV pneumatic:	front	617	84.5	250	6.4	575
	rear	617	105	250	11.2	575
VW Golf:	front	160	19.6	405	1400	246
	rear	160	24	405	1600	205

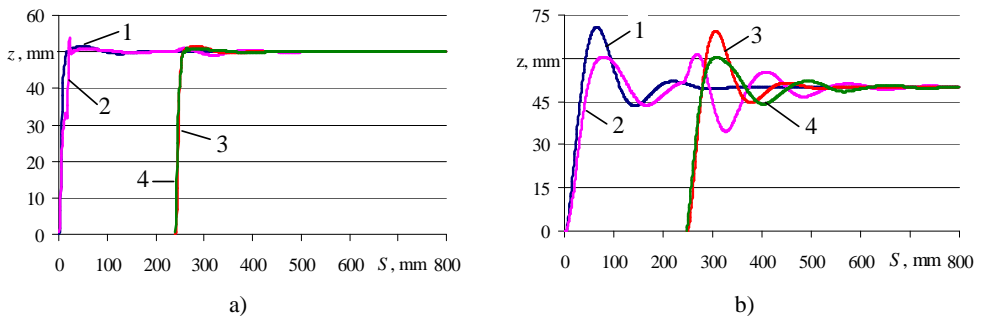

Fig. 6. Displacements of unsprung (a) and sprung (b) masses obtained by using both models when $\nu = 1.39$ m/s, $H = 50$ mm: 1 – front axle, quarter-car model, 2 – front axle, 2D model, 3 – rear axle, quarter-car model, 4 – rear axle, 2D model

The obtained results are presented in Fig. 7.

For the vehicle VW Golf the influence of the load on the axis can be observed – the lower load on rear axis decreases dynamical coefficient by 1.2 times when the step height increases. Significantly higher dynamical loads are observed on the tire. The influence of mass on the axis is manifested more vividly. Dynamical loads on rear tires are 1.3 times lower.

The influence of vehicle speed is lower (Fig. 7. c, d). The decrease of local dynamical load is related to frequency characteristics of the suspension.

In case of the application of nonlinear suspensions dynamical the loads can be reduced to a certain extent, nevertheless the characteristics of typical nonlinear suspensions are not sufficient to obtain a more pronounced effect.

Analysis of results for the EHVMV demonstrates that the combination with the pneumatic suspension elements is more effective (Fig. 8). Nevertheless, in order to obtain more significant effect in future it is necessary to investigate the possibilities of active suspensions to damp dynamical loads when crossing step-shaped unevenness.

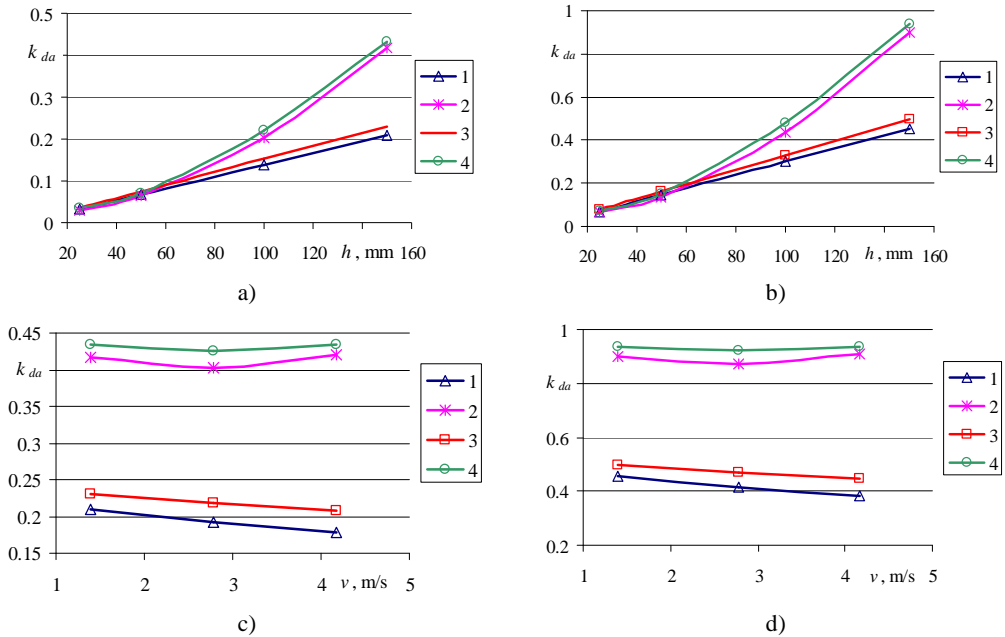

Fig. 7. Dependences of suspension deformations of the vehicle VW Golf on the step height ($v = 1.39$ m/s) (a, b) and speed of the vehicle ($h = 50$ mm) (c, d), in the case of linear and nonlinear suspension elements. Sprung mass (a, c), unsprung mass (b, d): 1 – linear, rear, 2 – non-linear, rear, 3 – linear, front, 4 – non-linear, front

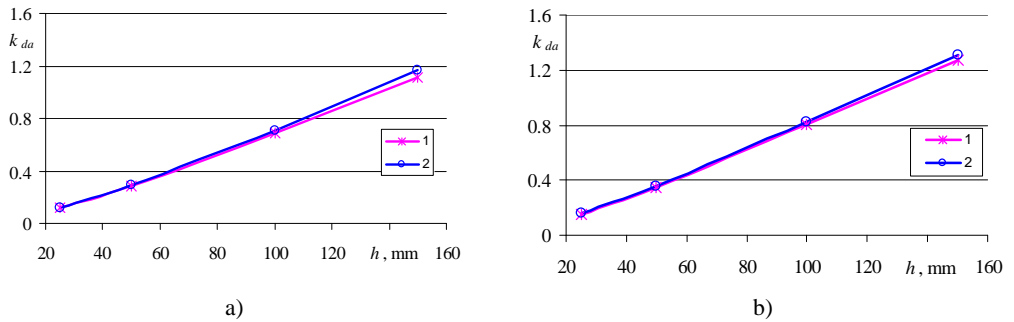

Fig. 8. Dependence of dynamical coefficient of the sprung mass on the step height in the case of the application of typical suspension (a) and pneumatic suspension (b): 1 – rear axle, 2 – front axle

Conclusions

1. In the range limits of the analyzed speeds the influence of leveling function of the tire strongly depends on the step height, as the distance necessary to cross the step increases up to the free radius of the tire when the step height increases up to 150 mm.
2. Leveling function of the tire essentially does not depend on the speed of a vehicle.
3. The step height has larger impact on dynamical loads in comparison to the vehicle speed.
4. Dynamical loads acting on the tire when crossing the step obstacle are 1.1 higher than those acting on the vehicle body.
5. A quarter-car model can be used for the evaluation of dynamical loads when moving across the step-shaped obstacle as dynamical coefficients obtained using this model do not

significantly differ from those obtained by the 2D model.

6. The influence of suspension parameters on dynamical loads was analyzed and it was established that the possibilities to damp dynamical loads together with the assurance of sufficient suspension performance characteristics under other movement conditions are limited. That is why it is reasonable to investigate the possibilities of the application of active suspensions.

7. A quarter-car model, which accounts for the influence of another axle, could be applied for approximate evaluation of dynamical overloads.

8. Possible height of the crossed step-shaped obstacle depends on dynamical radius of the wheel and uniformity of mass distribution in between the axles.

9. Influence of the pressure in tires at crossing of the step-shaped obstacle manifests only as an impact on the wheel-pavement grip.

References

- [1] **Kroneld P., Liedes T., Nevala K.** Optimal and Skyhook - Controlled Suspension for a 4-axle Heavy Off-road Vehicle. *Journal of Vibroengineering*. Volume 12, Issue 3, 2009, p. 400-406.
- [2] **Grigas V., Kazlauskienė, K., Šulginas A., Toločka R.T.** Computational Analysis of the Magnetorheological Fluid Loading Unit of Rowing Simulator. – *Mechanika*. – Kaunas: Technologija, 2010, Nr. 6(86), p. 66-70.
- [3] **Pacejka H. B.** *Tire and Vehicle Dynamics*. Second edition. UK: Elsevier, 2006, p. 642.
- [4] Наземные тягово – транспортные системы. Т. 1 / Под ред. И. П. Ксеновича. Москва: Машиностроение, 2003, 743 с.
- [5] **Genta G., Morello L.** *The Automotive Chassis*. Volume 2: System Design. Berlin Springer, 2009, p. 834.
- [6] **Ostaševičius V., Dargužis A., Marjullo J. S.** Study of Modernisation of Extra High Mobility Vehicles. *Proceedings of the International Conference “Transport Means – 2005”*: Kaunas: Technologija, 2005, p. 297-301.
- [7] **Dargužis A., Ligonnet F., Pilkauskas K.** Investigation of vehicle's dynamics in crossing vertical obstacles. *Proceedings of the International Conference “Transport Means – 2010”*. Kaunas: Technologija, 2010, p. 228-232.
- [8] **Литвинов Ф. С., Фаробин Я. Е.** *Автомобиль. Теория эксплуатационных свойств*. Москва: Машиностроение, 1989. – 240 с.
- [9] **Гришкевич А. И.** *Автомобили: Теория*. Минск: Вышэйша школа, 1984. 312 с.
- [10] *Краткий автомобильный справочник*. Под ред. А. Н. Понизовкина. Москва, А. О. Трансконсалтинг. НИААТ, 1994. – 779 с.